

PARTS MANUAL

MANUAL NUMBER VM2820-1
MODELS VM2820 STATIONARY UNIT

!!!WARRANTY REGISTRATION INSIDE MUST BE COMPLETED AND RETURNED WITHIN 15 DAYS OF INVOICE SALE DATE OR WARRANTY IS REDUCED!!! DON'T LOSE YOUR FULL WARRANTY!!!

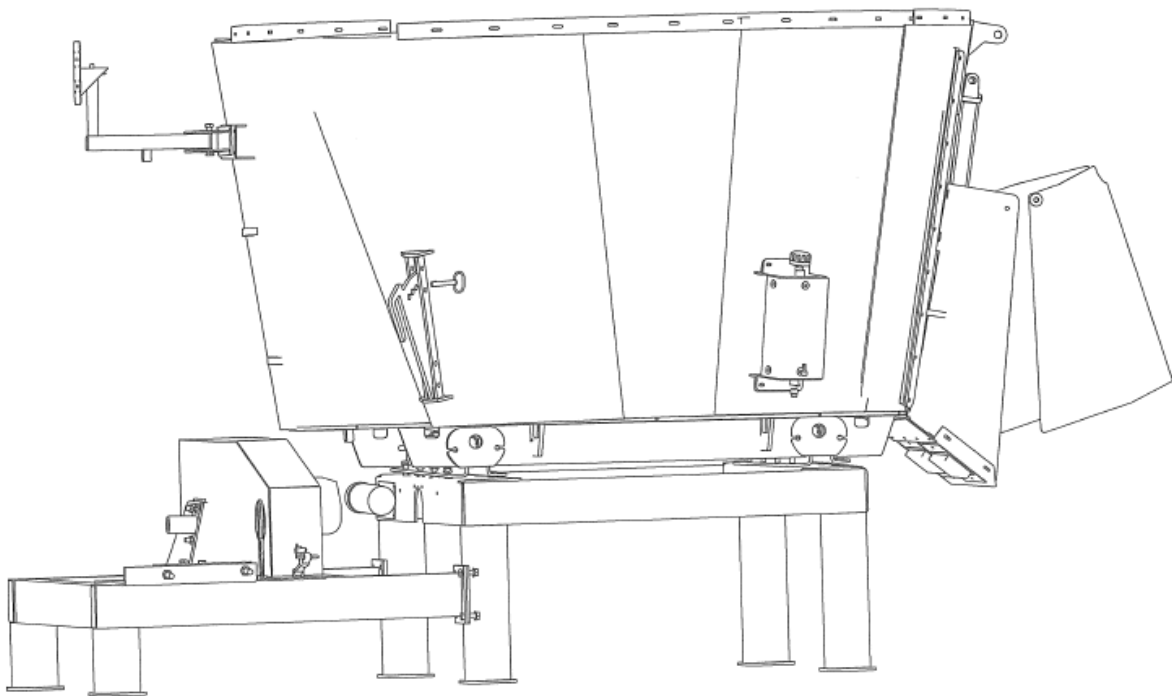

SCHULER MFG. & EQUIP. CO., INC.

63724 RICHLAND ROAD
GRISWOLD, IOWA 51535
PHONE - 712-774-2228
FAX - 712-774-2230

E-mail: schuler@schulermfg.net

Web Page: www.schulermfg.net

Date of Purchase

Model Number

Serial Number

Checked at Factory By

IMPORTANT NOTICE

*It is essential to return the White Copy of the
PURCHASER'S WARRANTY REGISTRATION
(located inside of the manual)
to Schuler Mfg. & Equip. Co., Inc., to validate the
machine warranty.*

MANUAL REVISIONS

PRINTING DATE: NOVEMBER, 2011

PRICE: \$7.00

CONTENTS
VM2820

PARTS

When Ordering Parts.....	1
Safety and Operational Decals.....	2-3
Mixer Tub Assembly Front Discharge.....	4-5
PTO Drivelines & Screw.....	6-7
Stationary Frame Assembly.....	8-9
Optional Hydraulic Power Unit.....	10
VM2820Mixer Tub Assembly Dual Discharge.....	11-12
VM2820Mixer Tub Assembly Side Discharge.....	13

WHEN ORDERING PARTS

Always have the following information available for phone orders or included in your written order.

1. **Machine Model**
2. **Serial Number**
3. **A general parts description can be very helpful to insure shipping the correct part. Often the customer does not know the part number, or has read the wrong number from the manual. Asking the following questions, where applicable, can help eliminate many questions on what the customer needs.**
 - a. **Number of teeth on sprocket or gear.**
 - b. **Bore size / OD of part.**
 - c. **Length of part, flight, auger, etc.**
 - d. **Is pulley a cast spoke / steel stamping.**
 - e. **Any other questions that may be applicable.**
4. **Address all parts orders to:**

Schuler Mfg. & Equip. Co., Inc.
63724 Richland Rd
Griswold, IA 51535
5. **For phone orders call – 712-774-2228.**
 - a. **Collect Calls – Please be advised that Schuler Mfg. & Equip. Co., Inc. does not accept collect telephone calls.**

Schuler Mfg. & Equip. Co., Inc. takes pride in fast customer service. Same day parts shipments can be made on UPS if the order is called in before 10:00 AM and the parts are in stock.

All part descriptions and dimensions are reference to inches unless specified otherwise.

SAFETY AND OPERATIONAL DECALS

SAFETY AND OPERATIONAL DECALS

SAFETY DECALS ARE PLACED ON THE MIXER/FEEDER FOR THE PROTECTION OF THE OPERATOR OR ANY PERSON NEAR THE UNIT.

Be sure everyone who operates this equipment understands all the information, warning, caution, and danger decals.

Keep the decals CLEAN so they are readable. This applies to all caution, warning, and danger decals.

It is the OWNER'S RESPONSIBILITY to provide information for safe operation of this machine.

Replace any damaged or worn decals. Once any part of a decal becomes non-readable, it should be replaced. The part numbers for the decals are located in the lower RH corner of the decal, and listed in this manual on the following pages. Replacement decals may be ordered through your dealer or the address below.

When replacing decals, be sure the surface area is clean and dry, peel the backing off the decal, and apply to the machine. Be sure to wipe with a clean cloth to rub out all air bubbles to assure a good seal. For best adhesion, decals should be applied in temperatures of 50 degrees (F) or warmer.

DECALS

ITEM	QTY	PART NUMBER	DESCRIPTION
1	2	10010-0103	DECAL, SCHULER, 6 x 32
2	2	10010-0143	DECAL, SCHULER, VM4020
	2	10010-0144	DECAL, SCHULER, VM5020
	2	10010-0145	DECAL, SCHULER, VM6020
	2	10010-0147	DECAL, SCHULER, VM2820
3	1	10010-0100	DECAL, SCHULER, QUALITY BUILT
4	4	10010-0230	DECAL, DANGER, ROTATING AUGER HAZARD
5	1	10010-0664	DECAL, IMPORTANT, TIGHTEN WHEEL LUGS
6	3	10010-0225	DECAL, DANGER, DO NOT USE THIS SHIELD FOR STEP
7	4	10010-0921	DECAL, YELLOW REFLECTIVE TAPE
8	5	10010-0920	DECAL, RED REFLECTIVE TAPE
9	1	FEMA	DECAL, GREASE GUN, 50 HOURS
10	1	10010-0680	DECAL, O, 1,2,3,C
11	4	10010-0317	DECAL, WARNING, KEEP OUT MOVING PARTS, FAILURE TO HEED...
12	1	10010-0550	DECAL, VM OPERATING INSTRUCTIONS
13	1	10010-0421	DECAL, IMPORTANT, READ OPERATORS MANUAL
14	6	10010-0520	DECAL, GREASE GUN, 500 HOURS
15	2	10010-0340	DECAL, WARNING, HIGH PRESSURE FLUID HAZARD
16	1	10010-0663	DECAL, IMPORTANT, OIL LEVEL (SIGHT GAUGE)
17	1	10010-0210	DECAL, DANGER, PTO, ROTATING DEVICE
18	1	10010-0500	DECAL, SLOW MOVING VEHICLE
<u>VMMDL-1125 INCLUDES</u>			
	1	10010-0671	DECAL, IMPORTANT, USE ONLY HIGH SPEED AT 4000 LB. LOAD
	1	10010-0663	DECAL, IMPORTANT, OIL LEVEL (SIGHT GAUGE)
	1	10010-0662	DECAL, 2-SPEED GEAR PATTERN
	1	10010-0700	DECAL, 2-SPEED

SAFETY DECALS

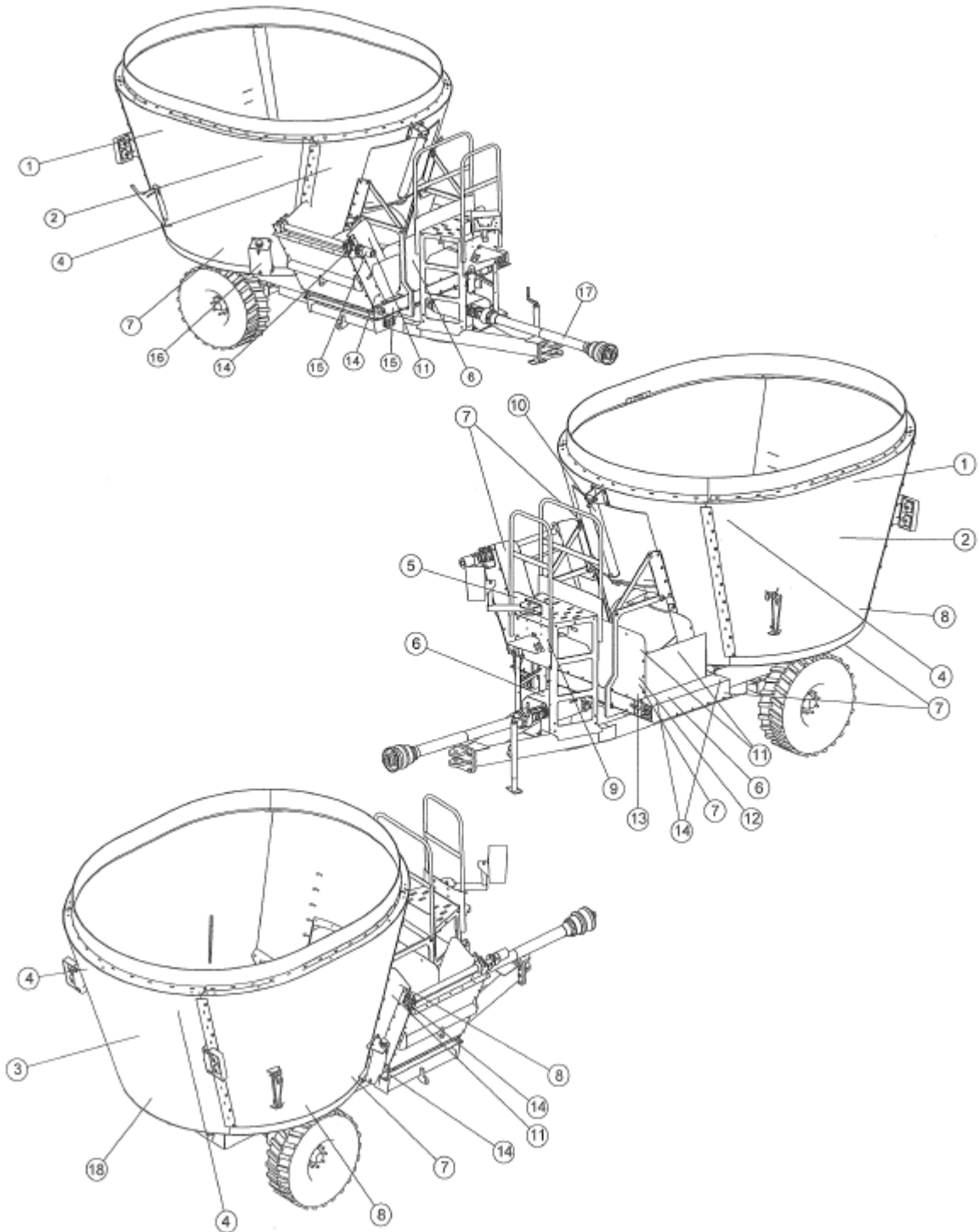

NOTICE: Immediately replace all worn or damaged decals. Please supply the unit's Serial Number with decal part number when ordering.

VM2820 MIXER TUB ASSEMBLY FRONT DISCHARGE
VM-300010

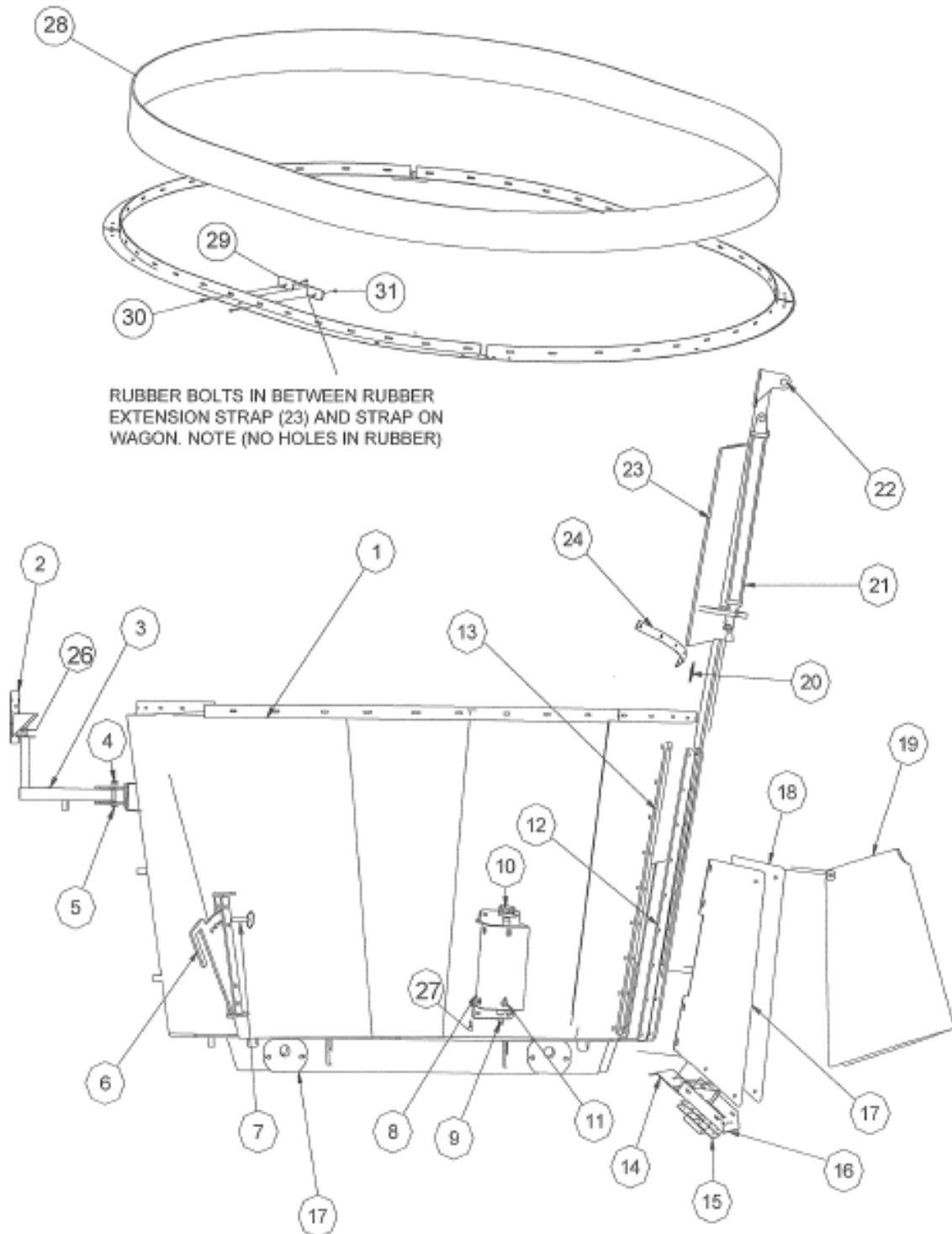

VM2820 MIXER TUB ASSEMBLY

ITEM	QTY	PART NUMBER	DESCRIPTION
1	1	0-700855	TUB ASSEMBLY, SINGLE DISCHARGE, STATIONARY, V2820, COMER
2	1	0-320350	SWIVEL MOUNT INDICATOR BKT
3	1	0-700272	INDICATOR ARM SWIVEL SMALL VM
4	1	71TC2-0120	3/4-10 TWA LOCKNUT, ZP
5	1	70HC2-1232	3/4-10 * 4 HHCS, GRD 2, ZP
6	2	0-700379	HAY RESISTOR PLATE 1/2 * 11 5/8 * 18
7	2	73D00-1029	BALL, SPRING PIN, 5/8 DIA * 2 1/2
8	1	0-700351	OIL RESERVOIR, MULTI SCREW
9	1	33HT5406-P-12	3/4-NPT MALE HEX HEAD PLUG
10	1	26SPG-0001	FILLER CAP, PLANETARY RESERVOIR
11	3	33HT4290-6-4	3/8 ID HOSE BARB TO 90 DEG ELBOW 1/4-NPT MALE PIPE
12	2	0-700092	DOOR GUIDE STRAP 3/8 * 3 * 50
13	2	0-700324	DOOR SPACER STRAP 1/2 * 1 1/2 * 50
14	1	0-871273	SLIDE CHUTE MOUNTING PLATE, 7 GA * 7 * 42
15	2	45000-0820	MAGNET, 8 1/2 * 19 1/2, STAINLESS
16	1	0-700270	DISCHARGE SLIDE CHUTE BOTTOM SS, 7 GA * 12 * 46
17	1	0-700793-L	REAR SLIDE CHUTE SIDE PIECE , 7 GA * 15 * 40
18	1	0-700793-R	REAR SLIDE CHUTE SIDE PIECE , 7 GA * 15 * 40
19	1	0-700443	REAR DOOR SHIELD
20	1	40002-0239	RUBBER SEAL TS DOOR, 2 1/8 * 38 5/8
21	1	33E00-0224	HYD CYLINDER, 2 * 24, SAE #8 O/R PORTS
22	1	0-700578	UPPER CYLINDER BRACKET, V875, V1050, V5020
23	1	0-700915	DISCHARGE DOOR ASSY V2820
24	1	0-700390	FRONT DOOR SEAL STRAP 7 GA * 1 1/2 * 38 11/16
25	4	0-700313	WEIGH BAR BRACKET FOR SRM 3/4 * 6 * 8
26	1	0-600450	FRICTION DISC SWIVEL MOUNT, 1/8 RUBBER * 3 1/2 DIA
27	1	33HT4290-8-4	1/2 ID HOSE BARB TO 90^ ELBOW 1/4-NPT MALE PIPE
OPTIONAL EXTENSION			
28	30	960B0-1200-000	2 PLY 220, 3/8 * 12 WIDE
29	22	0-700372	RUBBER EXTENSION STRAP, 1/4 * 2 * 12
30	44	70HC5-0512	5/16-18 * 1 1/2 HHCS, GRD 5, ZP
31	52	71UC2-0050	5/16-18 TOP LOCKNUT, ZP

PTO DRIVELINES, SCREW
VM-300020

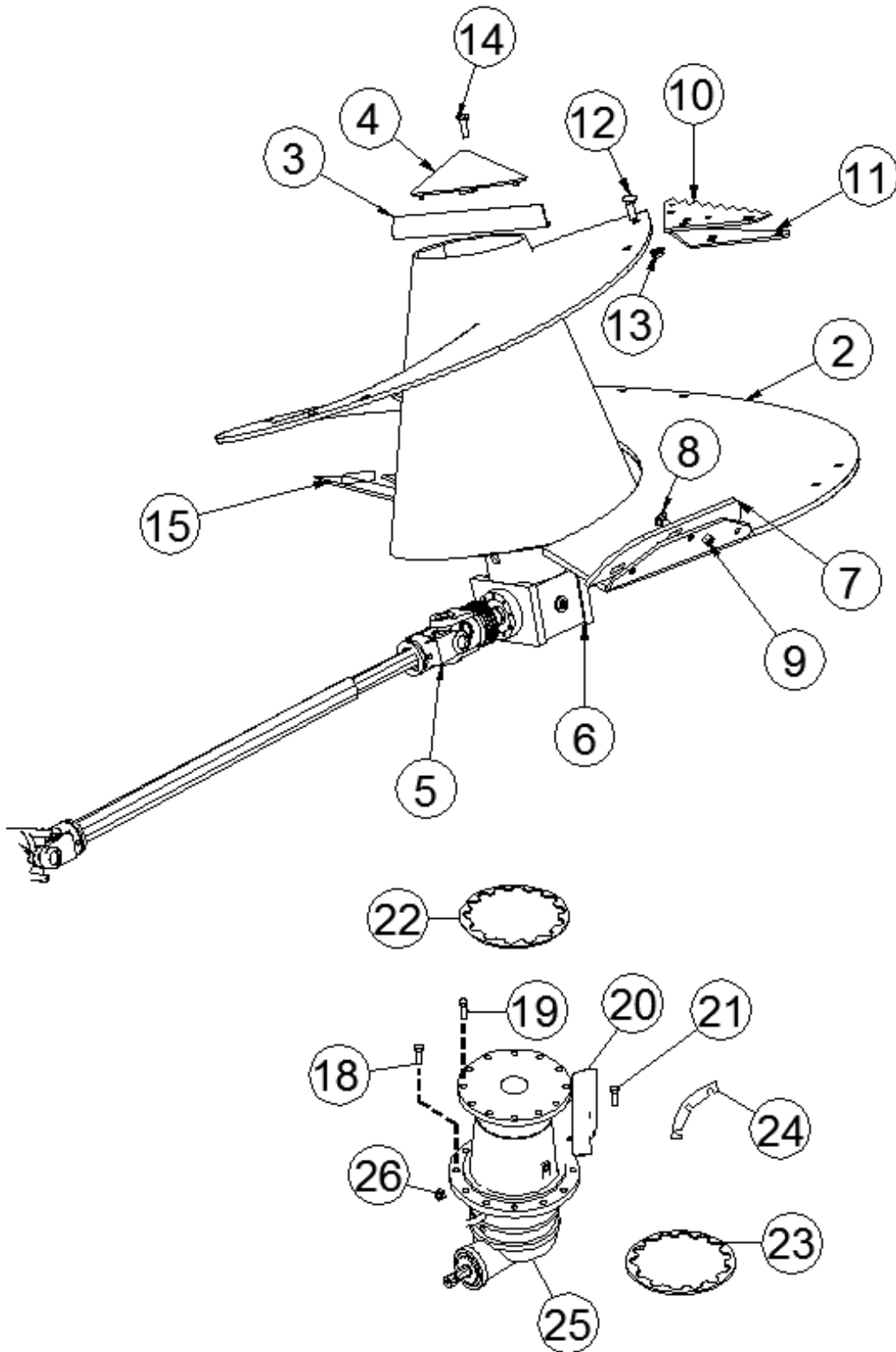

PTO DRIVELINES, SCREW

In order to have proper shear protection, use only genuine Schuler replacement shear bolts.

ITEM	QTY	PART NUMBER	DESCRIPTION
2	1	0-700905	SCREW ASSY, 2820
3	1	0-700792	CAP ANGLE, BOLT-ON, FOR 2820
4	1	0-700908	SCREW CAP FOR V360 & V2820
5	1	25B06-1135-24	PTO, 1 3/4-20 & 1 3/4-20, 2000 NM SHEAR SIZE 6, 2820 STAT
6	1	26CPG-3241	COMER PGA 1603 (TOTAL 25.89:1 RATIO 4 GEAR) CHINA
7	1	0-700162	EDGE DEFLECTOR, 1/2 * 4 * 21 3/4
8	3	70CC5-1014	5/8-11 * 1 3/4 CARRIAGE HD, GRD 5, ZP
9	3	71UC2-0100	5/8-11 TOP LOCKNUT, ZP
10	5	0-700377	SHORT CUTTING KNIFE, 6.0 MM
11	5	0-700589	SMALL BACKING PLATE 1/2 * 6 * 13 3/8 / FITS PN#700377
12	10	70CC5-1018	5/8-11 * 2 1/4 CARRIAGE BOLT, GRD 5, ZP
13	10	71WC2-0100	5/8-11 FLANGE LOCKNUT, ZP
14	1	70HC5-1032	5/8-11 * 4 HHCS GRD 5, ZP
15	1	0-700906	BI PULSE LEG WITH KICKER, 1/2 * 4 BEVEL EDGE * 30
18	12	70HC5-1024	5/8-11 * 3 HHCS, GRD 5, ZP
19	15	70HM8-1650	M16-2.0 * 50 HHCS, CLASS 8.8, ZP
20	1	0-700480	HOSE GUARD FOR 1603 COMER PLANETARY, 7 GA * 4 3/4 * 8 3/8
21	1	70HM8-1835	M18-2.5 * 35 HHCS, CLASS 8.8
22	1	0-700645	SCREW SHIM FOR 1603 COMER, 12 GA * 13 3/4 DIA.
23	2	0-700476	PLANETARY ADAPTOR PLATE 3/4 * 11 1/2 * 23
24	1	0-700642	PLANATARY SHIM, 16 GA * 2 * 16 1/4
25	12	70HM8-2490	M24-3.0 * 90 HHCS, CLASS 8.8, BLACK
26	12	71UM8-0240	M24-3.0 TOP NYLON INSERT LN CLASS 8.8, ZP
27	12	71UC2-0100	5/8-11 TOP LOCKNUT, ZP
29	1	33HT5400-N2-1.5	1/8-NPT MALE TO 1/8-NPT MALE PIPE NIPPLE 1.50" LONG
30	1	33HT5504-2	1/8-NPT FEMALE TO 1/8-NPT FEMALE ELBOW
31	1	33NH1-0720	1/8-3000 PSI * 72, (2) 1/8-NPT MALE ENDS
32	1	33HT1404-2-2	STEEL PIPE SWIVEL ADAPTOR 1/8-27 NPTF x 1/8-27 NPSM
33	1	74020-0000	1/8-NPT GREASE ZERK, STRAIGHT

VM2820 STATIONARY FRAME ASSEMBLY
VM-300030

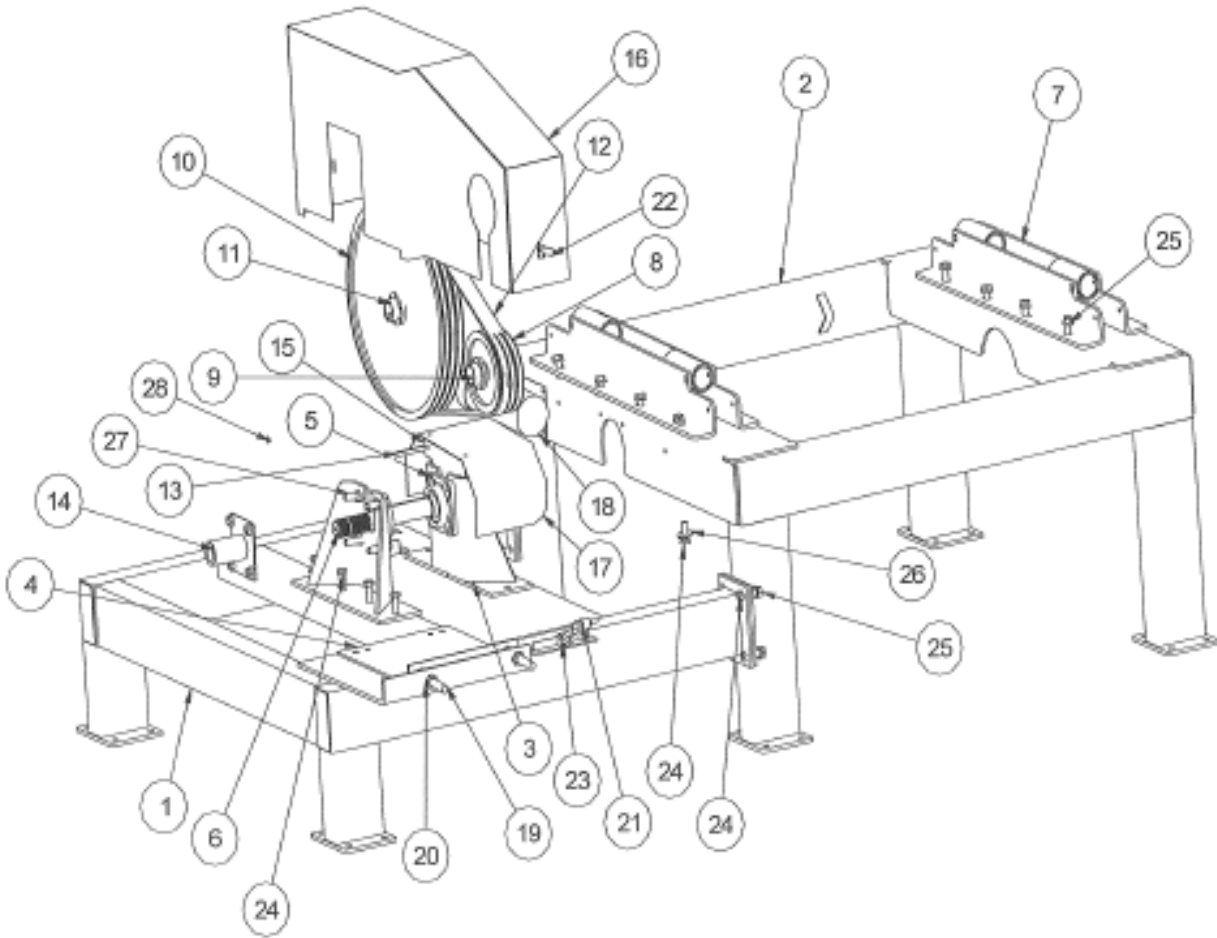

VM2820 STATIONARY FRAME ASSEMBLY

ITEM	QTY	PART NUMBER	DESCRIPTION
1	1	0-700857	FRAME ASSY, ELECTRIC MOTOR DRIVE STATIONARY V2820
2	1	0-700856	FRAME ASSY, MAIN FRAME STATIONARY V2820
3	2	0-700858	JACK SHAFT BEARING TOWER STATIONARY V2820
4	1	0-700859	ELECTRIC MOTOR BELT TENSION PLATE, STATIONARY V2820
5	2	1740H-1214	BRG 4-BOLT CAST HD, 1 3/4 B, 2SS
6	1	26SCH-0218	SPLINED CARRIER SHAFT, 1 3/4-20 SPLINED BOTH ENDS * 18
7	2	0-700513	WEIGH BAR BRACKET ASSY, V4020 & V5020
8	1	1335V-0850	QD SHEAVE 35V850SF
9	1	14001-QD15	QD BUSHING, SF-1 7/8
10	1	1335V-2120	QD SHEAVE 35V2120E
11	1	14003-QD14	QD BUSHING, E 1 3/4
12	1	155VX-1000	BELT, COGGED EDGE, 3/5VX1000
13	1	0-300390	KEY, 3/8 CD * 4
14	1	0-700861	PTO SHAFT COVER
15	1	0-700863	PTO SHIELD ANGLE, 7 GA * 5 1/4 * 9 1/4
16	1	0-700862	BELT SHIELD FOR STATIONARY VM
17	1	0-700738	TRANSFER BOX PTO COVER 10 GA * 9 * 26 3/8
18	1	41P00-3000	MANUAL CANISTER LARGE W/NEOPRENE SEAL
19	2	0-700864	ELECTRIC MOTOR ADJUSTMENT BOLT
20	6	71JC2-0120	3/4-10 JAM NUT, ZP
21	2	39011-0000	SHIELD LATCH, LARGE RUBBER
22	2	39011-0001	SHIELD LATCH BRACKET, LARGE
23	2	39011-0010	RUBBER LATCH HOLDER- U- SHAPE BRACKET
24	24	70HC5-1014	5/8-11 * 1 3/4 HHCS, GRD 5, ZP
25	40	71WC2-0100	5/8-11 FLANGE LOCKNUT, ZP
26	16	72FH0-0100	5/8 FLAT WASHER, ZP
27	8	70HC5-1020	5/8-11 * 2 1/2 HHCS, GRD 5, ZP
28	2	74040-0000	1/4-28 STRAIGHT GREASE ZERK

OPTIONAL HYDRAULIC POWER UNIT

VM-300040

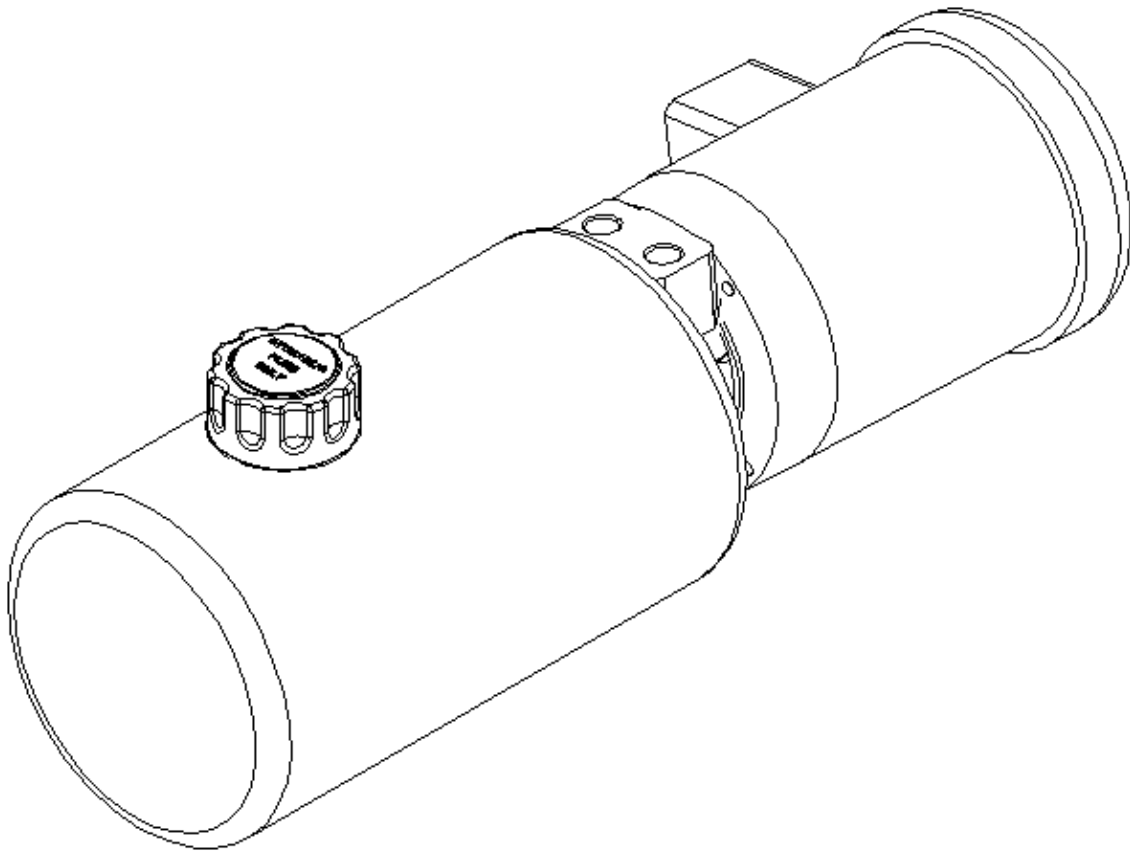

ITEM	QTY	PART NUMBER	DESCRIPTION
1	1	VMMDL-1020	HYD POWER UNIT, 1 HP SINGLE PHASE,DUAL DISCHARGE
	1	VMMDL-1021	HYD POWER UNIT, 1 HP SINGLE PHASE,SINGLE SIDE DIS
	1	VMMDL-1022	HYD POWER UNIT, 1 HP SINGLE PHASE,SINGLE FRONT DIS

VM2820 MIXER TUB ASSEMBLY DUAL DISCHARGE
VM-300050

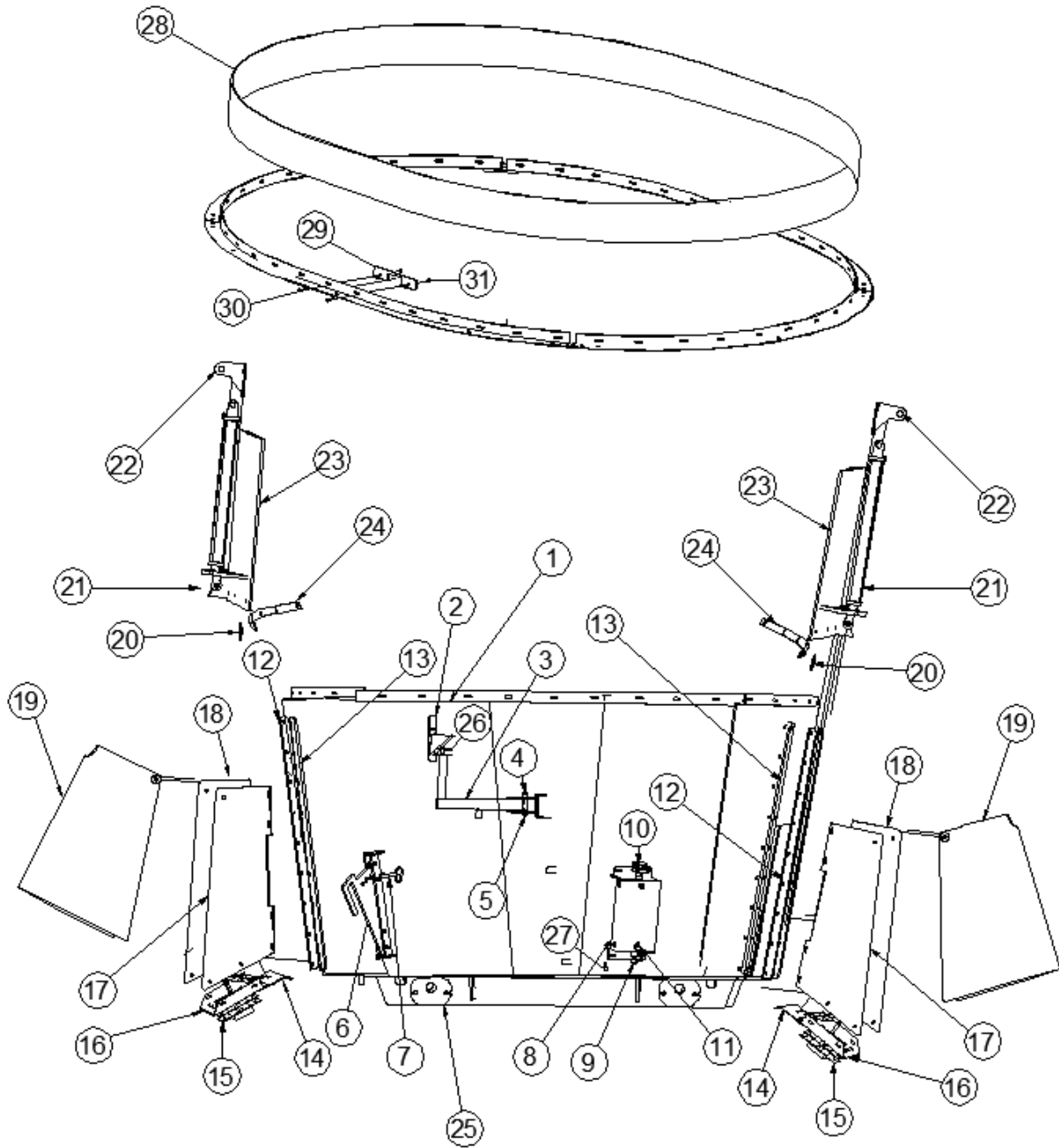

VM2820 MIXER TUB ASSEMBLY DUAL DISCHARGE

ITEM	QTY	PART NUMBER	DESCRIPTION
1	1	0-700854	TUB ASSEMBLY, DUAL DISCHARGE, STATIONARY, V2820, COMER
2	1	0-320350	SWIVEL MOUNT INDICATOR BKT
3	1	0-700272	INDICATOR ARM SWIVEL SMALL VM
4	1	71TC2-0120	3/4-10 TWA LOCKNUT, ZP
5	1	70HC2-1232	3/4-10 * 4 HHCS, GRD 2, ZP
6	2	0-700379	HAY RESISTOR PLATE 1/2 * 11 5/8 * 18
7	2	73D00-1029	BALL, SPRING PIN, 5/8 DIA * 2 1/2
8	1	0-700351	OIL RESERVOIR, MULTI SCREW
9	1	33HT5406-P-12	3/4-NPT MALE HEX HEAD PLUG
10	1	26SPG-0001	FILLER CAP, PLANETARY RESERVOIR
11	3	33HT4290-6-4	3/8 ID HOSE BARB TO 90 DEG ELBOW 1/4-NPT MALE PIPE
12	4	0-700092	DOOR GUIDE STRAP 3/8 * 3 * 50
13	4	0-700324	DOOR SPACER STRAP 1/2 * 1 1/2 * 50
14	2	0-871273	SLIDE CHUTE MOUNTING PLATE, 7 GA * 7 * 42
15	4	45000-0820	MAGNET, 8 1/2 * 19 1/2, STAINLESS
16	2	0-700270	DISCHARGE SLIDE CHUTE BOTTOM SS, 7 GA * 12 * 46
17	2	0-700793-L	REAR SLIDE CHUTE SIDE PIECE , 7 GA * 15 * 40
18	2	0-700793-R	REAR SLIDE CHUTE SIDE PIECE , 7 GA * 15 * 40
19	2	0-700443	REAR DOOR SHIELD
20	2	40002-0239	RUBBER SEAL TS DOOR, 2 1/8 * 38 5/8
21	2	33E00-0224	HYD CYLINDER, 2 * 24, SAE #8 O/R PORTS
22	2	0-700578	UPPER CYLINDER BRACKET, V875, V1050, V5020
23	2	0-700915	DISCHARGE DOOR ASSY V2820
24	2	0-700390	FRONT DOOR SEAL STRAP 7 GA * 1 1/2 * 38 11/16
25	4	0-700313	WEIGH BAR BRACKET FOR SRM 3/4 * 6 * 8
26	1	0-600450	FRICTION DISC SWIVEL MOUNT, 1/8 RUBBER * 3 1/2 DIA
27	1	33HT4290-8-4	1/2 ID HOSE BARB TO 90^ ELBOW 1/4-NPT MALE PIPE
OPTIONAL EXTENSION			
28	30	960B0-1200-000	2 PLY 220, 3/8 * 12 WIDE
29	22	0-700372	RUBBER EXTENSION STRAP, 1/4 * 2 * 12
30	44	70HC5-0512	5/16-18 * 1 1/2 HHCS, GRD 5, ZP
31	52	71UC2-0050	5/16-18 TOP LOCKNUT, ZP

VM2820 MIXER TUB ASSEMBLY SIDE DISCHARGE
POWER FROM FRONT
VM-30060

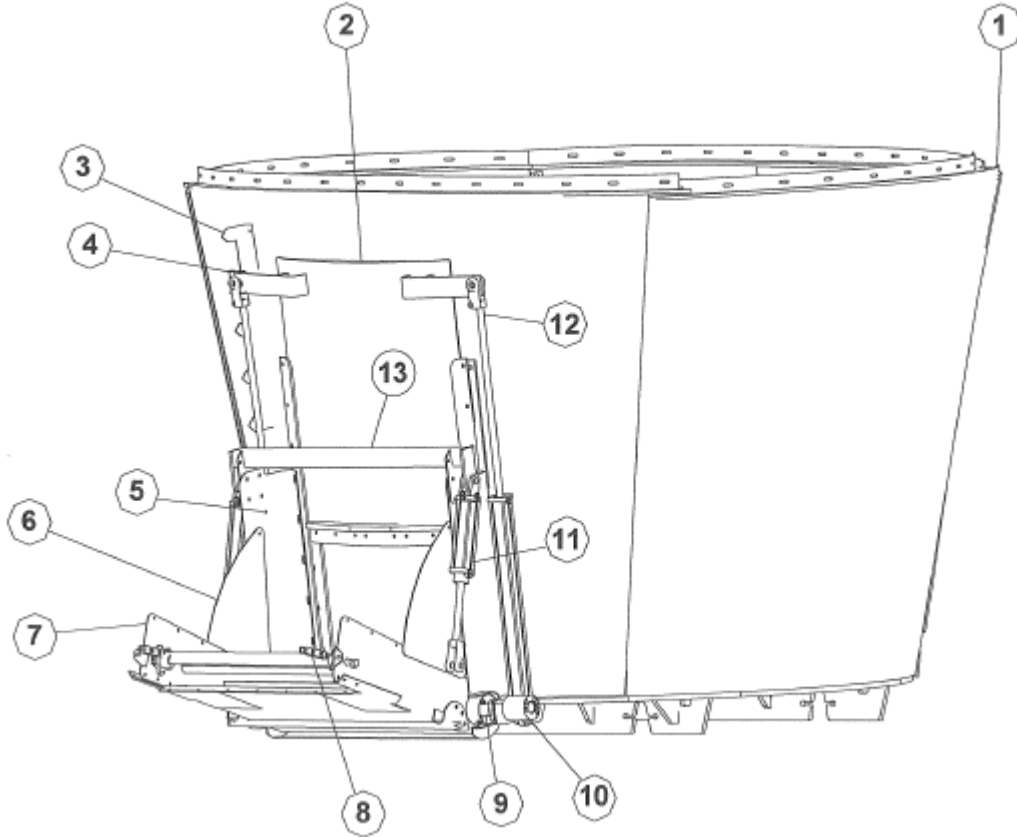

ITEM	QTY	PART NUMBER	DESCRIPTION
1	1	0-700909	TUB ASSEMBLY, SIDE DISCHARGE, V2820, COMER
2	1	0-700348	DISCHARGE DOOR, 3510, 1/2 * 36 * 36 1/2
3	1	0-700035	DOOR GAUGE VERTICAL 12 GA * 6 1/2 * 30
4	1	0-700085	VERTICAL MIXER DOOR GAUGE 14 GA * 5 * 6
5	1	0-700331	DISCHARGE CONVEYOR MOUNT FOR LONG CONVEYOR FOR VM
6	2	0-700326	CONVEYOR SIDE PANEL 10 GA * 13 7/8 * 22 7/8
7	1	0-700284	CONVEYOR ASSY, OAL 37 1/4
8	1	23H08-031A	D667H CONVEYOR CHAIN, 31 P, 8 ATT, PR INC 2 PINS
9	1	26000-1000	SHAFT COUPLER, 1 5/8 OD * 1 ID * 3 OAL, 1/4 KW PN #511450
10	1	33BAM-000	HYD MOTOR, 18.0 CU IN
11	2	33E00-0208	HYD CYLINDER, 2 * 8, SAE #8 O/R PORTS
12	2	33E00-0224	HYD CYLINDER, 2 * 24, SAE #8 O/R PORTS
13	1	0-700346	DISCHARGE LIFT TUBE